

Network Appliance™ iSCSI Solutions for Affordable IP-Based SAN Storage

High-performance storage systems for fast, simple, cost-effective data consolidation.

Key Features

- **LEVERAGES EXISTING IP NETWORK INVESTMENT**

Builds on stable standards, pervasive gigabit network infrastructure, and familiar network management tools.

- **REDUCES TCO**

Cost-effective SAN solution provides significant savings over direct-attached storage through storage consolidation, streamlined management, and standard interoperable components.

- **REDUCES RISK**

The NetApp unified storage architecture reduces the risk of deploying new technology.

Solution

iSCSI, or Internet SCSI, a new protocol defined by the Internet Engineering Task Force, offers the consolidation, scalability, and management advantages of a storage area network (SAN) without the unfamiliarity, complexity, and expense of Fibre Channel. NetApp SAN solutions based on iSCSI provide a cost-effective alternative to direct-attached storage in areas of your IT infrastructure where Fibre Channel would be unnecessary or economically unfeasible. iSCSI SAN solutions are particularly attractive in Windows®, Linux®, and Novell environments, where server proliferation is making storage management prohibitively complex and expensive. Entry-level NetApp iSCSI storage systems in particular are ideal storage consolidation solutions for these environments in smaller organizations and workgroups.

Benefits

iSCSI simplifies the storage of massive amounts of data by enabling the construction of cost-effective SAN storage solutions in departmental, regional, or remote data centers where Fibre Channel solutions are not a cost-effective option. iSCSI enables IT organizations to leverage their investment and expertise in Ethernet networking infrastructure to deploy either departmental SANs that complement their existing Fibre Channel data center SAN or greenfield SANs within their distributed IT environment.

iSCSI combines the speed and low cost of SCSI with the familiarity and ubiquity of IP networking and Ethernet, making iSCSI storage solutions cost-effective, scalable, and familiar.

iSCSI extends the NetApp unified storage architecture to support applications that require SAN storage in addition to those that require NAS storage, over the same infrastructure, for a significantly less-complex data management environment.

Problems Solved

Direct-attached storage works well in environments with an individual server or a limited number of servers, but the situation rapidly becomes unmanageable if there are dozens of servers or significant data growth. The storage for each server must be managed separately and cannot be shared. Performance and scalability are often limited, and storage resources cannot be efficiently allocated. The data management needs of today's enterprise IT environments are typically much better served by a networked storage approach.

SAN storage has considerable advantages over direct-attached storage, including improved scalability, reliability, availability, and performance. However, cost and complexity issues have limited SAN deployments to mission-critical and high-performance applications, typically in "glass house" data center environments. iSCSI provides a cost-effective SAN solution for the rest of the IT environment.

For more information, please see the Network Appliance white paper on this topic, *iSCSI: Accelerating the Transition to Network Storage* (TR 3241).

PARTNER SOLUTIONS

Network Appliance partners with other industry leaders to give you fully integrated storage solutions that leverage your information to drive productivity while offering maximum data protection.

Product Description

Network Appliance, the world leader in Ethernet-connected storage solutions, initially extended its solutions to include Fibre Channel SAN storage and has now extended them further to include iSCSI technology. With tens of thousands of systems deployed worldwide, NetApp now offers its customers a low-risk option for building Ethernet-based SAN storage networks.

The iSCSI protocol is supported by NetApp FAS200, F800, and FAS900 series storage systems, and by NetApp NearStore® R200 systems. These systems, along with standard Gigabit Ethernet infrastructure (cables and switches) and iSCSI "initiators" in servers, form the foundation for flexible, cost-effective, easy-to-use iSCSI-based SAN storage solutions.

NetApp FAS200, F800, and FAS900 Series Storage Systems

As fabric-attached storage appliances, NetApp FAS200, F800, and FAS900 series storage systems offer storage consolidation. They have multiprotocol support (SAN and NAS protocols) and deliver unified data management. A scalable suite of highly available, field-proven networked storage systems, NetApp systems are easy to install, configure, and manage and deliver one of the lowest TCOs and highest ROIs in the industry.

NetApp NearStore Systems

NearStore systems offer cost-effective, fast-access storage for online backup and archiving. NearStore dramatically improves existing tape backup processes by inserting economical and simple-to-use disk-based storage between application storage and tape libraries, in a two-stage backup configuration.

iSCSI Initiators

A networked storage solution using iSCSI requires the host server to run an "iSCSI initiator." This is analogous to an NFS client in a NAS solution or an FCP initiator in a Fibre Channel SAN solution.

Both hardware and software initiators are available. Software initiators for Windows, Novell NetWare™ and Linux are now components of the OS provided by the OS vendors. (We also expect to see software initiators from the UNIX® vendors in the future.) Alternatively, NetApp supports several iSCSI hardware initiators.

NetApp has also launched a self-qualification program whereby third-party iSCSI adapter vendors can be certified as NetApp technology-supported solutions. For more details see the iSCSI partnerships page at www.netapp.com/solutions/iscsi.

Software initiator solutions are best suited to lightly loaded servers running a single application. Heavier workloads and compute-intensive or multiprogramming server environments are more likely to require a hardware solution for optimal performance.

Service and Support

A broad range of service, support, and professional services options are available from the NetApp worldwide support organization and partners to ensure that the customer's transition from direct-attached to networked storage is fast, efficient, and delivers the maximum benefits from NetApp storage appliance architecture.

About Network Appliance

See how NetApp iSCSI storage solutions can help your organization manage its data storage infrastructure. Visit our Web site at www.netapp.com and let us show you what "The evolution of storage™" can mean for your business.

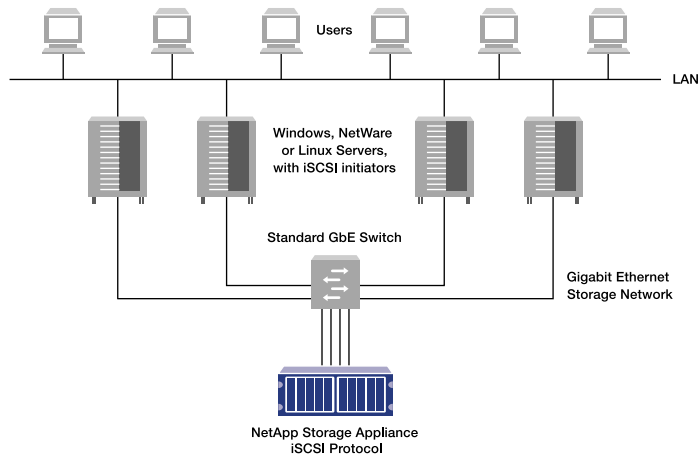

Figure 1) Deployment scenario.



Network Appliance, Inc.
495 East Java Drive
Sunnyvale, CA 94089
www.netapp.com

© 2004 Network Appliance, Inc. All rights reserved. Specifications subject to change without notice. NetApp, NearStore, and the Network Appliance logo are registered trademarks and Network Appliance and The evolution of storage are trademarks of Network Appliance, Inc., in the U.S. and other countries. Linux is a registered trademark of Linus Torvalds. Windows is a registered trademark of Microsoft Corporation. NetWare is a trademark of Novell, Inc. UNIX is a registered trademark of The Open Group. All other brands or products are trademarks or registered trademarks of their respective holders and should be treated as such. DS-2450 Rev. 0304