



ESG Lab Report™



Network Appliance® Data ONTAP™ 7G and V-Series Virtualization

A validation study
by
ESG Lab
September 2005

Authors:
Tony Asaro Brian Garrett

Copyright © 2005, Enterprise Strategy Group, Inc. All Rights Reserved.

Table of Contents

Introduction	3
ESG Lab Validation	4
<i>NetApp NAS and SAN</i>	4
<i>FlexVol</i>	5
<i>FlexClone</i>	11
<i>V-Series</i>	12
ESG Lab Validation Highlights	14
Roadmap Recommendations	14
ESG Lab's View	14
Appendix	16

ESG Validation Reports

The goal of the ESG Lab Validation reports is to educate customers about specific storage-related products including storage systems, backup-to-disk solutions, storage management applications, backup/recovery software, storage virtualization platforms, etc. The ESG Lab reports are not meant to replace the necessary evaluation process that end user customers should conduct. The ESG Lab reports are designed to provide insight to what is compelling about various products and how they can solve customer problems. ESG Lab reports also recommend areas we feel the vendor should improve upon. ESG Lab provides third-party expert perspective based on our own hands-on testing in a lab and interviews with customers using these products in production environments.

All trademark names are property of their respective companies. Information contained in this publication has been obtained by sources The Enterprise Strategy Group (ESG) considers to be reliable but is not warranted by ESG. This publication may contain opinions of ESG, which are subject to change from time to time. This publication is copyrighted by The Enterprise Strategy Group, Inc. and was sponsored by Dell. Any reproduction or redistribution of this publication, in whole or in part, whether in hard-copy format, electronically, or otherwise to persons not authorized to receive it, without the express consent of the Enterprise Strategy Group, Inc., is in violation of U.S. Copyright law and will be subject to an action for civil damages and, if applicable, criminal prosecution. Should you have any questions, please contact ESG Client Relations at (508) 482.0188.

Introduction

NetApp® is one of the leading storage vendors with an approach that is unique when compared to its major competitors. NetApp offers its FAS and NearStore® products, each with its own line of entry-level, midsize, and large systems to choose from. However, all of these products are interoperable and use the same operating system and software applications. This allows customers to benefit from all of the NetApp functionality within a single solution and learn only one set of tools, thus getting more value out of their investment. This differs from most other leading storage vendors that have a number of discrete products with very little in common.

NetApp is so strongly associated with NAS that customers don't think of them as a SAN storage vendor. However, NetApp has been supporting FC and iSCSI for years now, and have extremely competitive, feature-rich, and high performance midrange SAN offerings. Additionally, ESG believes that NetApp is the leader in iSCSI SANs with more deployments in the market than any other primary storage vendor. NetApp also has a large deployment of FC-based installations and the number is increasingly rapidly. Customers can use the NetApp storage systems for NAS, SAN, or a combination of both. This allows customers to use whichever protocol they feel is best suited for them, and access a common set of management tools and software features to support NAS and SAN.

NetApp has a wide range of software features, including all of its "Snap" solutions like Snapshot™, SnapMirror®, SnapLock®, SnapVault®, etc. This ESG Lab report analyzes new NetApp software, including FlexVol™ and FlexClone™. Additionally, NetApp offers the V-Series, which is both a NAS gateway and storage virtualization solution that provides all of the NetApp capabilities using third-party, heterogeneous storage systems.

Figure One: NetApp NAS, SAN and Storage Virtualization

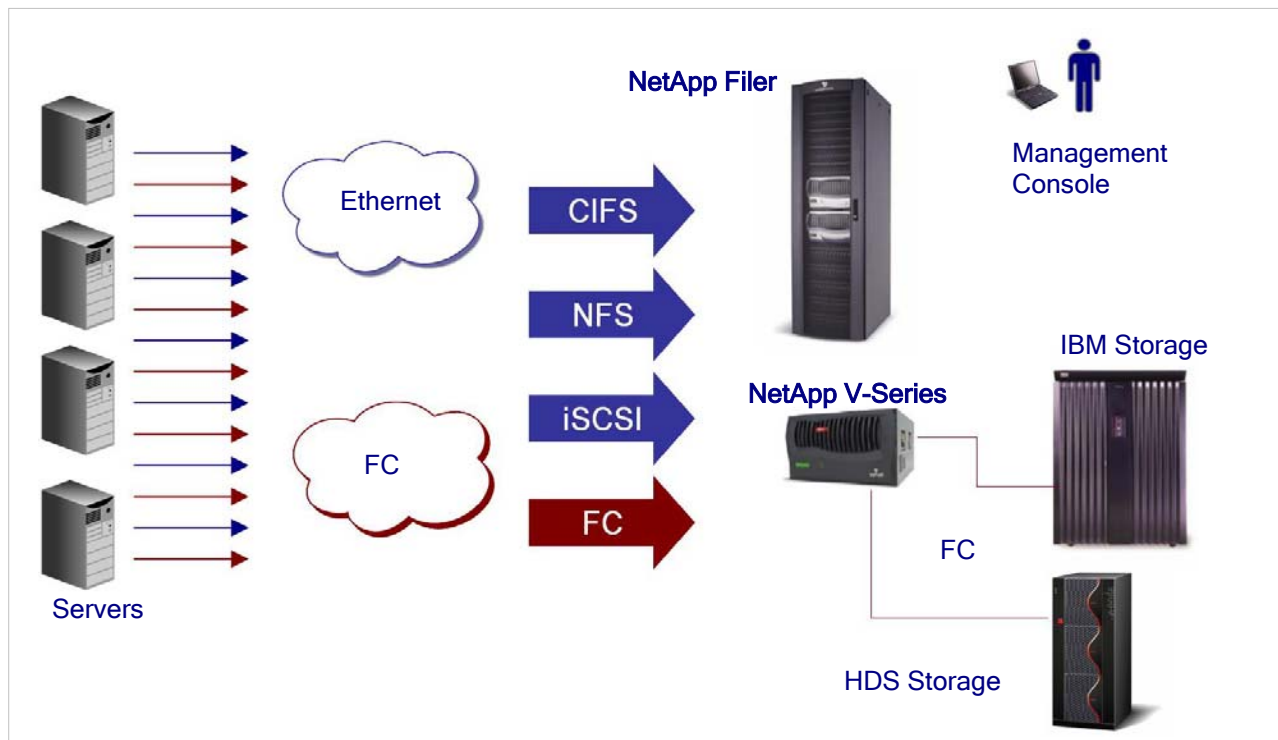

ESG Lab Validation

ESG Lab validated the latest Data ONTAP platform software, with a focus on FlexVol, FlexClone, and V-Series functionality, at Network Appliance headquarters in Sunnyvale, California. ESG Lab hands-on testing demonstrated the improved manageability, performance, and capacity utilization with the NetApp FlexVol and FlexClone software features. ESG Lab also tested the storage virtualization capabilities of the NetApp V-Series supporting third-party storage systems from IBM and Hitachi Data Systems (HDS).

NetApp NAS and SAN

NetApp is focused on supporting NAS and SAN in a single system, unlike some of the other leading storage vendors that require customers to implement discrete storage systems to support both. By consolidating NAS and SAN, customers can use many of the same management tools and software features for both. Additionally, NetApp supports both FC and iSCSI, in addition to the standards-based NAS protocols CIFS and NFS, which they have provided for years. NetApp has committed to this single platform approach, providing as much functionality as possible through software in order to add customer value. This report examines just three of the many capabilities of NetApp Data ONTAP, including FlexVol, FlexClone, and V-Series support.

FlexVol

FlexVol is the NetApp virtualization methodology used to create logical pools of storage within its integrated disk enclosure or with third-party storage subsystems. As will be demonstrated in this report, FlexVol can improve application performance, simplify storage provisioning, and enable better capacity utilization.

FlexClone

FlexClone is essentially a NetApp Snapshot copy of data that is not limited to a read-only status. Customers can use FlexClone copies to make logical full volumes of data and perform reads and writes against that data. FlexClone volumes are created nearly instantly and use disk space very efficiently, since only the blocks that change between the source and copy need to be additionally stored.

V-Series

The V-Series is a storage virtualization appliance with all of the same features and functions of the NetApp Filers that also allows customers to use third-party heterogeneous disk storage. NetApp has supported NAS gateway functionality for some time and has now extended the same capability to its SAN functionality.

FlexVol

FlexVol is the technology that adds significant new functionality to Network Appliance volumes. Adding and subtracting capacity from a FlexVol volume are simple and nearly instantaneous processes. Capacity can be dedicated and reserved for a FlexVol volume, or a FlexVol volume can be configured to present a virtual pool of shared capacity that is bigger than the actual amount of physical storage available. In this mode, sometimes referred to in the industry as thin-provisioning or over-provisioning, storage capacity is delivered on demand from a common pool of storage. In the next few sections of this report, we'll present the results of ESG Lab experiments that were designed to validate how FlexVol can be used to maximize capacity utilization, simplify storage capacity allocation and reallocation, and optimize application performance.

Setting the Stage

ESG Lab performed FlexVol testing in the following two configurations: a FAS980C and a V-Series appliance both configured in front of IBM ESS and HDS 9960 storage arrays.

Initial configuration and testing of FlexVol was done on the V-Series appliance. A Windows 2000 server was used to exercise volumes and run the web-based FilerView® GUI. The first FlexVol volume was configured on a pre-cabled and configured V-Series appliance over an existing aggregate pool of RAID protected capacity using the wizard shown in Figure Two. As shown, the only parameters needed for configuring a FlexVol volume are the aggregate to be used for capacity, the maximum amount of capacity that the volume will be allowed to consume, and a space guarantee policy. The following space guarantee options are available:

- **volume** - This option, which is the default, allocates and reserves the requested amount of capacity for a volume from the aggregate. This option is most like the traditional method used for years to allocate storage for a particular user, group, project, or application. Unlike traditional volumes, however, a FlexVol volume with volume level space guarantee can be expanded or shrunk on the fly and the allocation does not correspond to physical reservation of capacity.
- **file** - This option does not guarantee space for the entire volume, but does reserve capacity for individual files designated with a reservation.
- **none** - Operating systems and applications see a volume with the desired capacity, regardless of whether that amount of storage capacity is physically available. The system would make no effort to guarantee space for individual volumes or files within volumes. Using this option, volumes can be thin-provisioned so that the overall sum of provisioned storage is greater than the physical storage available.

Figure Two: FlexVol Configuration Wizard

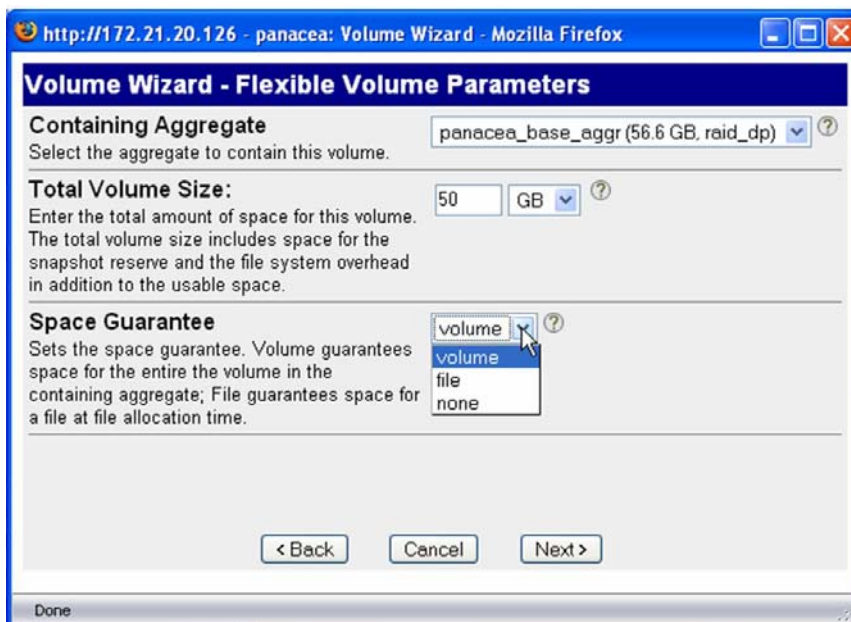

Thin Provisioning

ESG believes that thin provisioning is one of the most useful functions of a storage system and yet so few systems currently support this capability. Thin provisioning is a way to minimize the cumbersome task of storage provisioning while improving capacity utilization. When provisioning storage using traditional methods, system administrators allocate a fixed amount that is dedicated to an application.

For example, if a 500 GB volume is allocated to an application with only 100 GB of actual data, the other 400 GB has no data stored on it. That unused capacity still belongs to that application and no other application can use it. This means that the unused capacity of that 500 GB is wasted storage, which means that it is also wasted money. And even though all of the storage capacity is eventually used, it may take years to do so, which is a waste of storage capacity and money.

With thin provisioning, the storage provisioning process starts out the same. Using that same example, the systems administrator provisions 500 GB to the application with only 100 GB of actual data. With thin provisioning, the unused 400 GB is still available for other applications. This approach allows the application to grow transparently and at the same time ensure that capacity is not wasted. Thin provisioning is really Just-in-Time storage. The application thinks it has 500 GB of storage but the storage system only gives it the capacity it needs as it needs it. The rest of it stays in the pool. System administrators set thresholds to be alerted to tell them when to add more disks into the storage pool.

Figure Three: Traditional and Thin Provisioning

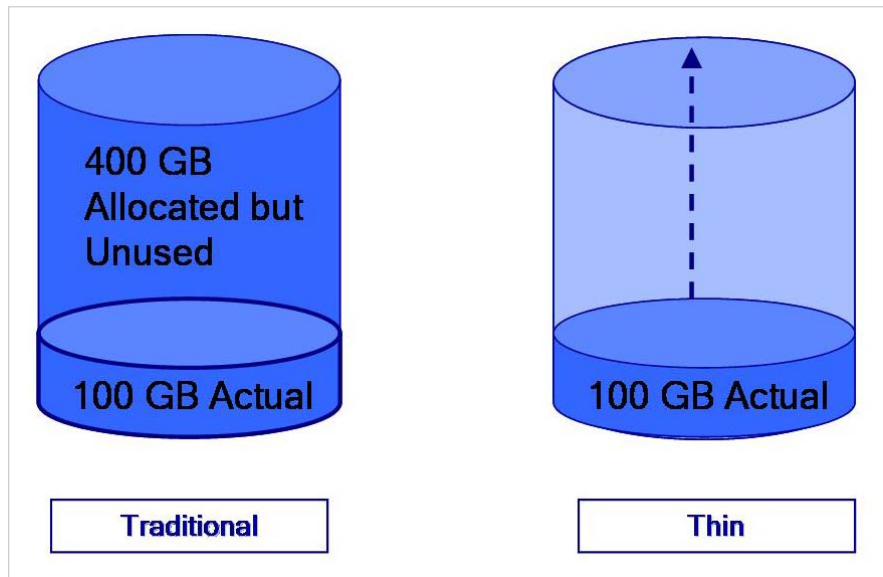

ESG Lab Testing

ESG Lab created a scenario for this test that simulates an IT organization that provides users with 400 GB of home space on a network attached shared drive. ESG Lab used the traditional method of provisioning volumes and the NetApp thin provisioning implementation for each of the users' home directories. ESG Lab configured the home directories at 400 GB, each using a pool of 2 TB of actual capacity within the NetApp FAS980c.

First, ESG Lab configured the NetApp FAS980c in the traditional method and was able to set up five user home directories with a total of 400 GB of capacity for each, using three RAID groups with 16 drives each.

Next, ESG Lab used FlexVol with thin provisioning enabled and, with the same FAS980c, set up 50 user home directories with a total of 400 GB of capacity. Again, we used the same three RAID groups each with 16 drives and the same amount of capacity.

Figure Four: FlexVol Thin Provisioning Scalability

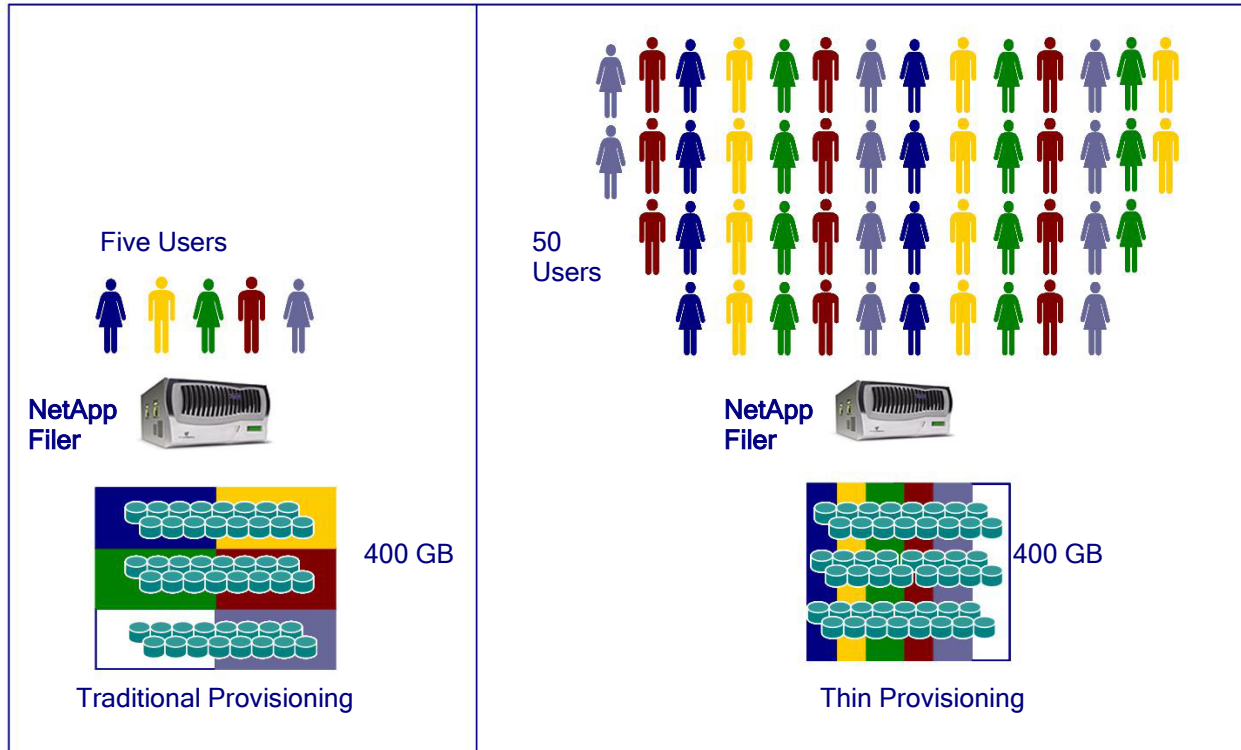

This ESG Lab test illustrates one of the benefits of thin provisioning. We were able to set up 10 times more user home directories with thin provisioning than with the traditional method. Using traditional provisioning methods would require 20 TB of usable capacity to support 50 home directories, compared to the 2 TB of capacity required when using thin provisioning.

A Windows server was then used to view and exercise the 16 400 GB FlexVol volumes as shown in Figure Five. Each of the network drives has a Total Size of 400 GB and has Free Space of 399 GB. With a traditional storage system a large percentage of that storage would be empty waiting for the application to fill it up. With NetApp thin provisioning, that capacity is in a non-dedicated logical pool, which optimizes capacity far more efficiently.

Figure Five: FlexVol Volumes as Seen by a Windows Server

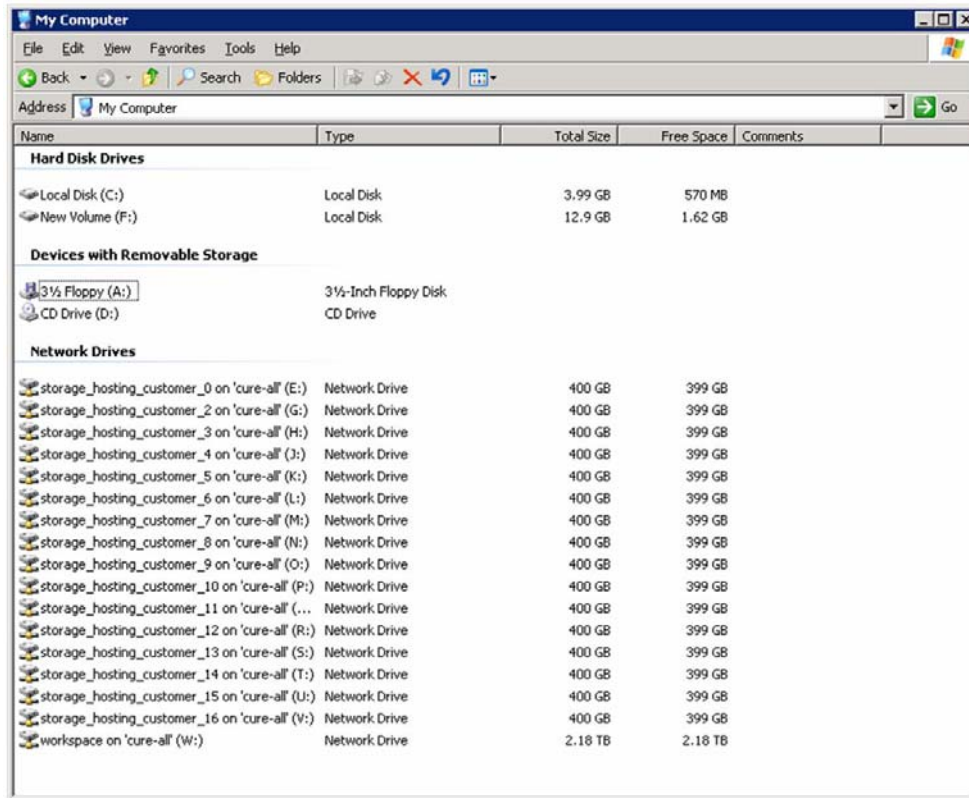

Name	Type	Total Size	Free Space	Comments
Hard Disk Drives				
Local Disk (C:)	Local Disk	3.99 GB	570 MB	
New Volume (F:)	Local Disk	12.9 GB	1.62 GB	
Devices with Removable Storage				
3 1/2 Floppy (A:)	3 1/2-Inch Floppy Disk			
CD Drive (D:)	CD Drive			
Network Drives				
storage_hosting_customer_0 on 'cure-all' (E:)	Network Drive	400 GB	399 GB	
storage_hosting_customer_2 on 'cure-all' (G:)	Network Drive	400 GB	399 GB	
storage_hosting_customer_3 on 'cure-all' (H:)	Network Drive	400 GB	399 GB	
storage_hosting_customer_4 on 'cure-all' (J:)	Network Drive	400 GB	399 GB	
storage_hosting_customer_5 on 'cure-all' (K:)	Network Drive	400 GB	399 GB	
storage_hosting_customer_6 on 'cure-all' (L:)	Network Drive	400 GB	399 GB	
storage_hosting_customer_7 on 'cure-all' (M:)	Network Drive	400 GB	399 GB	
storage_hosting_customer_8 on 'cure-all' (N:)	Network Drive	400 GB	399 GB	
storage_hosting_customer_9 on 'cure-all' (O:)	Network Drive	400 GB	399 GB	
storage_hosting_customer_10 on 'cure-all' (P:)	Network Drive	400 GB	399 GB	
storage_hosting_customer_11 on 'cure-all' (...)	Network Drive	400 GB	399 GB	
storage_hosting_customer_12 on 'cure-all' (R:)	Network Drive	400 GB	399 GB	
storage_hosting_customer_13 on 'cure-all' (S:)	Network Drive	400 GB	399 GB	
storage_hosting_customer_14 on 'cure-all' (T:)	Network Drive	400 GB	399 GB	
storage_hosting_customer_15 on 'cure-all' (U:)	Network Drive	400 GB	399 GB	
storage_hosting_customer_16 on 'cure-all' (V:)	Network Drive	400 GB	399 GB	
workspace on 'cure-all' (W:)	Network Drive	2.18 TB	2.18 TB	

Why This Matters

NetApp FlexVol thin provisioning enables customers to get much greater capacity utilization and significantly simplifies storage provisioning. ESG believes that thin provisioning is one of the most useful capabilities provided by a storage system that most, if not all customers, can benefit from. Thin provisioning increases capacity utilization, eliminates stranded storage, slows down or takes away the need to buy a new storage system based on capacity, and ultimately simplifies storage provisioning administration.

Thin provisioning reduces cost and complexity in the following ways:

- Less storage is required initially when purchasing a new storage system
- Since there will be no stranded storage capacity, less storage is required over the life of the storage system
- Additional storage systems will not be required based on having stranded storage
- More servers per storage system provide greater levels of consolidation
- Reduces the time and resource required to perform storage provisioning tasks

FlexVol Performance

NetApp FlexVol uses virtualization technology internal to the storage system, which manages disk capacity as logical pools of storage. This capability directly impacts application performance since the slowest part of any storage system is its electromechanical disk drives. Using FlexVol virtualization, data is automatically striped across all of the drives in the underlying aggregate pool, thereby leveraging all of the actuators and making read/write functions a much more parallel process. Striping data across numerous drives increases performance and essentially eliminates the need for performance tuning and determining hot spots.

Figure Six: FlexVol Configuration versus Traditional Storage Systems

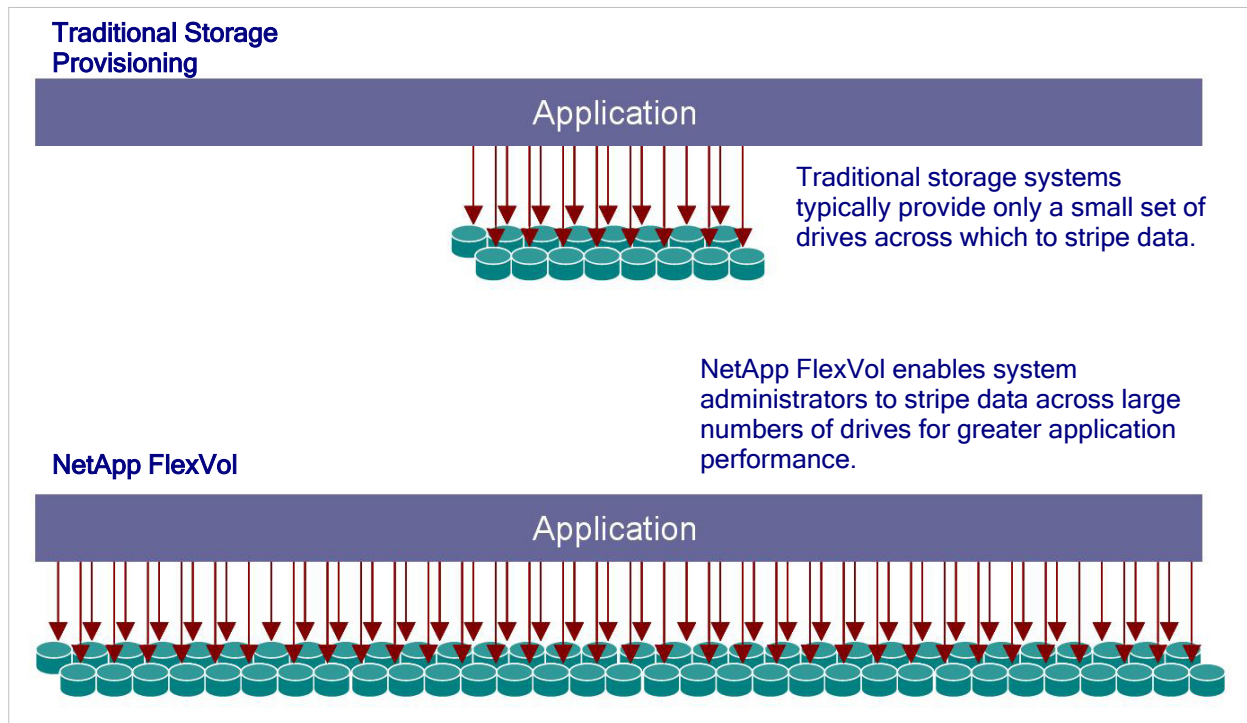

ESG Lab Testing

ESG Lab used the industry standard Iometer workload generator to emulate real-world file server and OLTP database workloads¹. ESG Lab used the same set of 48 drives to compare the performance of the traditional and FlexVol configurations. The traditional configuration allocates a specific number of drives to each application based on its capacity requirements. With FlexVol configuration, all applications share a single 48 drive aggregate pool.

Name	Workload	Drives
Department One	File Server	16
Department Two	File Server	16
Corporate Share	File Server	16
Database Tables	4 KB OLTP	4
Database Logs	4 KB Writes	2

¹ Configuration and workload details can be found in the Appendix.

ESG Lab used the same workloads to test the traditional method with a limited number of drives versus FlexVol striping across 48 drives. As Figure Seven illustrates, that FlexVol with striping significantly outperformed the traditional method.

Figure Seven: FlexVol Performance Results

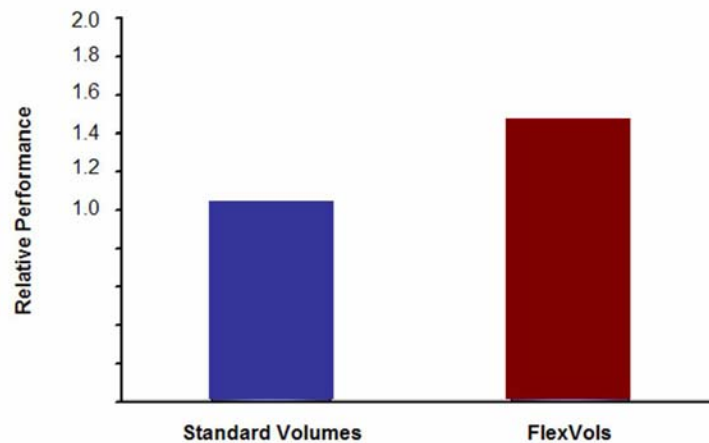

What the Numbers Mean

- A comparison of Iometer results revealed a 44% improvement² in the number of disk I/Os per second when switching from traditional volumes to a 48-drive FlexVol aggregate.
- A deeper exploration of Iometer results and NetApp FilerView performance statistics revealed that the database drive was overwhelmed in the traditional volume configuration. Users from all departments created a performance bottleneck when accessing database tables residing on only four disk drives in the traditional volume configuration, compared to users accessing database tables distributed over a FlexVol volume spread over 48 drives. Network Appliance FilerView and Iometer statistics confirmed the source of the bottleneck:
 - FilerView reported disk I/O utilization rates of 100% for the four-drive traditional volume used for the database tables compared to only 30% for the 48-drive FlexVol configuration. A disk I/O utilization rate of 100% means that the traditional volume was busy 100% of the time.
 - Iometer recorded significantly higher (as much as 400%) maximum I/O response times for traditional volume configuration compared to that for the FlexVol configuration. Response times in excess of a second for each disk I/O end up causing delays that can be felt by database and Email users.

Why This Matters

The slowest parts of any storage system are the disks, since they are electro-mechanical. Striping data across a large number of drives leverages all of the disk actuators making data access a parallel process. This increases performance and essentially eliminates the need for tuning and determining hot spots. ESG Lab testing showed a 44 percent improvement using FlexVol versus traditional volume performance. These performance gains are achieved without compromising the manageability of the data set. Each data set still gets its own volume and system administrators can implement Snapshot copies, backup schedules, and other data management features, while improving application performance by striping data across a large number of drives.

² Noting that the configuration was not designed to produce a large number, relative comparisons are presented instead of actual I/O rates to avoid results being taken out of context. In ESG Lab's opinion, the configuration and relative results presented provide a valid apples-to-apples comparison that can be used to gauge the effect of a FlexVol configuration change.

FlexClone

NetApp FlexClone essentially produces a logical full volume copy of data that users can use for reading and writing data. FlexClone copies are an efficient way to make copies of primary data without having to make a physical copy of the entire volume. FlexClone copies can be made rapidly and require very little additional storage capacity. The capacity used by a FlexClone copy represents only the blocks that have changed since the FlexClone image was taken. FlexClone copies use a combination of metadata about the primary data and a Snapshot copy to create the logical copy. From the systems administrator's and users' perspectives, a FlexClone copy is an exact replica of a FlexVol volume that can be used independently.

Prior to the availability of FlexClone copies, customers needed to convert a read-only Snapshot copy into a writeable full volume copy. This process consumes both time and capacity.

ESG Lab Testing

ESG Lab compared the process of converting a read-only Snapshot copy into a read/write copy of a 100 GB simulated accounting database file. We then created a FlexClone copy of the same file and compared the two methods.

Converting the Snapshot copy into a read/write full volume copy took about an hour. The conversion process resulted in two files at 100 GB each, for a total of 200 GB. ESG Lab used NetApp CLI to run the **df** command to see how capacity was impacted.

ESG Lab then created a FlexClone copy of the same 100 GB file, which was completed in a matter of seconds. ESG Lab observed that there was still just over 100 GB of consumed capacity. Changes to the FlexClone version of the 100 GB file were then made, which resulted in capacity growth based on the new data created.

Why This Matters

Customers require extra copies of data for application testing, data mining, and even data protection. FlexClone copies consume very little capacity and are created rapidly. NetApp FlexClone copies have the same advantage over full volume read/write copies that NetApp Snapshot copies have over full volume point-in-time copies. NetApp FlexClone copies are logical copies that require minimal additional capacity and are made in seconds.

V-Series

The NetApp V-Series is a storage virtualization solution that utilizes the NetApp Filer storage controller with all of its associated software features to manage third-party heterogeneous storage systems. NetApp is the only storage virtualization solution that supports NFS, CIFS, FC, and iSCSI within a single solution. The NetApp V-Series is both a NAS gateway and a SAN virtualization platform.

The NetApp V-Series enables customers to use all of the software options provided by NetApp, including FlexVol, Snapshot, FlexClone, SnapMirror, SnapVault, etc., with their existing third-party storage systems. ESG Lab tested the NetApp V-Series with IBM ESS 800 and HDS Thunder 9970V.

Figure Eight: NetApp V-Series Storage Virtualization

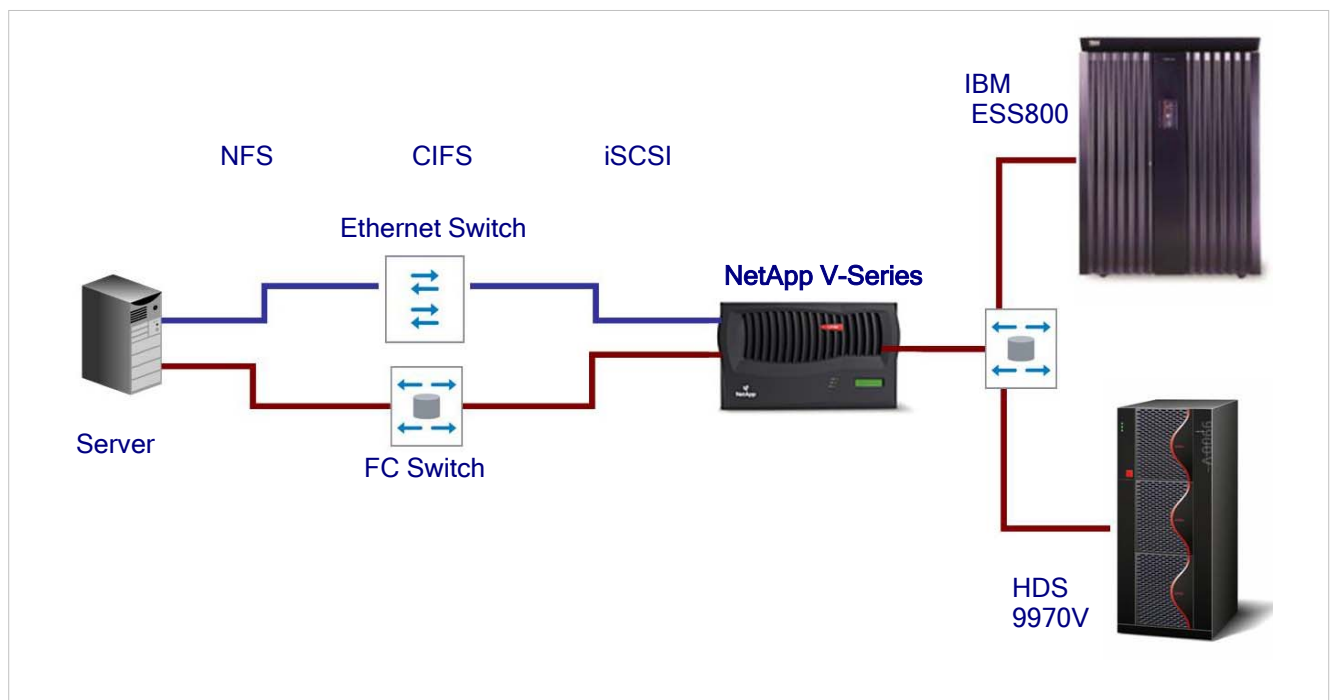

ESG Lab Testing

ESG Lab testing began with a quick tour of the cabled and configured NetApp V-Series configuration using the FilerView GUI. A Windows 2000 server was used to access volumes virtualized by the V-Series appliance and residing on storage arrays from HDS and IBM. ESG Lab performed reads and writes through the V-Series appliance to the HDS and IBM storage systems using NFS, CIFS, FC, and iSCSI.

The look and feel of the V-series with the HDS and IBM drives was the same as the FAS system tested earlier with drives from NetApp. The only differences ESG Lab noted were:

- The FilerView license page had a new line item that indicated a Gateway license was active.
- The Manage Disks screen had longer names for drives discovered automatically by Data ONTAP and disk tray and shelf information was marked with a ?.

Figure Nine: FilerView Management of a V-Series Configuration

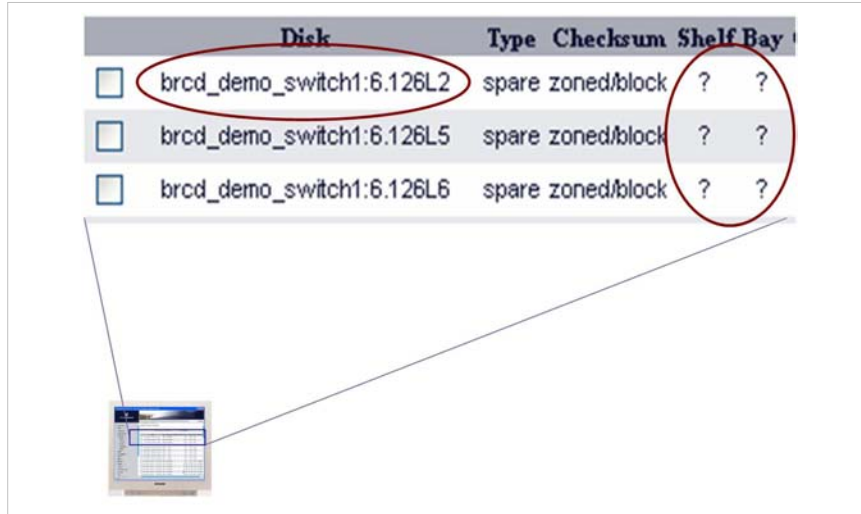

	Disk	Type	Checksum	Shelf Bay
<input type="checkbox"/>	brcd_demo_switch1:6.126L2	spare zoned/block	?	?
<input type="checkbox"/>	brcd_demo_switch1:6.126L5	spare zoned/block	?	?
<input type="checkbox"/>	brcd_demo_switch1:6.126L6	spare zoned/block	?	?

ESG Lab found the process of setting up the V-Series appliance to be easy and intuitive. ESG Lab performed a number of tests with the V-Series appliance, the IBM ESS800, and the HDS 9970V, including:

- FlexVol volumes
- Growing and shrinking volumes
- Snapshot copies
- FlexClone copies

Why This Matters

ESG research found that customers are interested in storage virtualization in order to simplify management and reduce hardware and software spending. Using the V-Series, customers can leverage the rich set of field-proven NetApp capabilities, support NAS and SAN within a single system, and use their existing storage systems for capacity.

ESG Lab Validation Highlights

- ☑ Demonstrated the thin-provisioning capabilities of FlexVol and its ability to cost effectively deliver 20 TB of virtual storage on only 2 TB of storage capacity actually owned.
- ☑ Quantified a 44 percent performance improvement for departmental shared drives and a database, using FlexVol defined over a 48 drive virtual pool of disk drives compared to those same 48 drives configured in static RAID groups.
- ☑ Demonstrated the capacity savings and flexibility that can be realized through the use of FlexClone volumes compared to traditional read-only Snapshot copies.
- ☑ Validated that FlexVol and FlexClone functionality, which is supported across the entire NetApp product lineup, is supported on volumes accessed through CIFS, NFS, iSCSI, and FC.
- ☑ Demonstrated unified iSCSI, FC, NFS, and CIFS access to storage arrays from HDS and IBM, using a V-Series appliance running Data ONTAP 7G.
- ☑ Validated that the FlexVol and FlexClone features are supported on the V-Series when attached to heterogeneous storage.

Roadmap Recommendations

The following recommendations were made by ESG Lab:

- **Network Clustered Architecture.** Implement to scale beyond a 2-node active-active cluster.
- **Scalable File System.** Expand beyond 16 TB for ease of management.
- **Native Global Name Space.** Manage multiple NetApp file systems within and across Filers from a single view.

ESG Lab's View

NetApp has been known for its leadership in NAS storage with a strategy of providing as much functionality as it can within its filer products. This is very different from many other storage vendors that have discrete products for different applications at additional financial, footprint, and management expense. Additionally, NetApp is no longer a NAS-only storage vendor and has an extremely innovative and competitive SAN storage system. NetApp is rapidly adding more features and functions, bringing real value that can reduce cost and complexity. ESG Lab has seen the results of this through greater performance, more efficient capacity utilization, simplified storage provisioning, logical full volume copies, and storage virtualization of third-party storage. NetApp is known for being a leader in NAS storage but ESG Lab will put a stake in the ground on its SAN implementation - NetApp provides an excellent midrange SAN-based storage system that can compete with any of the leading midrange solutions out there today.

Customers can still use NetApp for NAS-only applications. ESG would also encourage customers to evaluate NetApp as a SAN-only solution, since it offers some of the most useful and advanced features when compared to other competitive products. However, ESG believes the combination of NAS and SAN within a single solution provides great value if the customer has a need for both. The NetApp unified approach simplifies management and reduces cost by providing one system versus two, with all of the associated software licenses and maintenance fees.

NetApp supports storage virtualization, an emerging category of storage solutions that ESG believes will become more widely adopted over time. Again, NetApp provides both NAS and SAN support with heterogeneous storage unlike the majority of other competitive storage virtualization products. Customers can use the NetApp V-Series and get all of the software value and use existing storage systems that they already have in their data center. Storage virtualization is being more widely adopted because the value of it is too compelling to ignore. Customers can simplify management, reduce hardware and software costs, perform data replication services across heterogeneous storage, and implement intelligent tiered storage matching the right to storage to the appropriate business needs.

ESG Lab tested NetApp FlexVol to create large pools of storage for greater application performance, and thin provisioning to simplify storage management and improve capacity utilization rates. ESG Lab

implemented FlexClone, creating capacity-efficient and extremely fast logical copies of primary volumes that offer the same value that Snapshot copies have versus full volume point-in-time copies. Additionally, ESG Lab tested the V-Series, implementing FlexVol, FlexClone, and Snapshot with IBM and HDS storage. FlexVol, FlexClone, and V-Series are prime examples of how NetApp continues to add value through software innovation.

Appendix

Iometer workloads ran on eight Dell 1550 servers which accessed shared network drives using the CIFS protocol. A file server workload was performed on three of the six Dell servers against the accounting, HR, and corporate drives respectively. One of the servers ran a Database log workload. All of the servers ran four Database 4K OLTP workers.

Iometer Workload Definitions				
Workload	Size (Bytes)	% Size	% Reads	% Random
Database - 4K OLTP	4096	100%	67%	100%
Database Log	4096	100%	0%	0%
File Server	512	10%	80%	80%
	1024	5%	80%	80%
	2048	5%	80%	80%
	4096	60%	80%	80%
	8192	2%	80%	80%
	16384	4%	80%	80%
	32768	4%	80%	80%
	65536	10%	80%	80%

FlexVol Performance Test Bed	
Storage Controller	FAS980c
Data ONTAP Code Revision	7.1.0
Number of Drives Tested	48
Type of Drives Tested	FC/36 GB/10 K RPM
Ethernet Switch	Extreme Summit 7i
Fibre Channel Switch	Brocade SilkWorm 3800s
Number of Servers	6
Server Type	Dell 1550
CPU	1.2 GHz Intel
RAM	1 GB
Operating System	Windows 2000, SP4

V-Series Configuration	
Storage Controller	V-Series (GF960)
Data ONTAP Code Revision	7.1.0
Storage Array	IBM ESS800 (Shark)
Code Revision	2.3.2.115
Drives	32 SSA/36 GB/10 K RPM
Total Raw Capacity	1.1 TB
Storage Array	9970v (Thunder)
Code Revision	21-13-03/00/00
Drives	56 FC/36 GB/10 K RPM
Total Raw Capacity	2.0 TB
Server Type	Dell 1550
CPU	Dual Xeon TBD GHz
RAM	1 GB
Operating System	Windows 2000, SP4
Fibre Channel Adapter	Emulex Lightpulse
Fibre Channel Driver	5.5.10.10
iSCSI Driver	MSFT v1.06